

Gr 8 Special Chain Fittings/Attachments

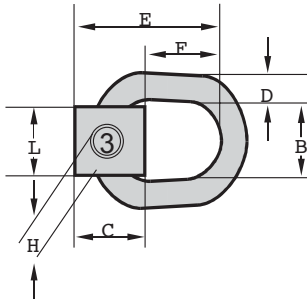

TRANSPORT RING, WELD-ON TYPE

PRODUCT CODE	Size	Dimensions mm								Mass kg
		WLL	E	F	C	L	H	D	B	
DO6115177-01	10-8	3,15	84	46	45	44	38	18	48	0,7
DO6115177-02	13-8	5,3	120	69	60	60	51	24	66	1,6
DO6115177-03	16-8	8	127	66	68	65	61	28	72	2,4
DO6115177-04	22-8	15	178	98	96	109	80	39	120	8,1

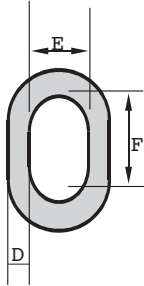

WELDED COUPLING LINKS

PRODUCT CODE	Link Size (mm)			Link Size (mm)		
	D	E	F	D	E	F
DO6115169	7,0	14	28			
DO6115170	10,0	16	30	28	60	100
DO6115171	13,0	25	40	32	65	110
DO6115172	16,0	35	60	40	70	130
DO6115173	20,0	40	70	45	80	150
DO6115174	22,0	45	80	50	90	180
DO6115175	25,5	50	90			

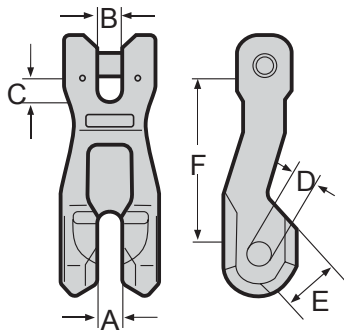

CLEVIS SHORTENING CLUTCH

PRODUCT CODE	Chain size mm	Code No.	Dimensions mm					Mass kg
			A,B	C	D	E	F	
DO61150-33	7/8	KC 7	8	10	9	16	62	0,4
DO61150-34	10	KC 10	12	14	12	25	87	0,9
DO61150-35	13	KC 13	16	17	15	32	115	1,9
DO61150-36	16	KC 16	20	19	19	39	143	3,2

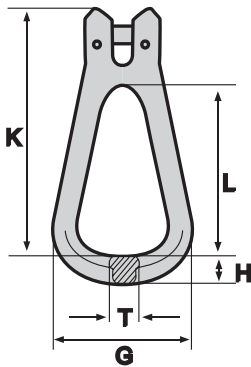

CLEVIS REEVABLE MASTER LINK

PRODUCT CODE	Chain size mm	Code No.	Dimensions mm					Mass kg
			K	L	G	T	H	
DO61150-21	7,0 - 0 8,0	YG01	124	87	75	14	15	0,4
DO61150-22	10,0	YG02	155	108	96	18	19	0,7
DO61150-23	13,0	YG03	196	136	108	23	22	1,3
DO61150-24	16,0	YG04	239	165	124	24	26	2,6

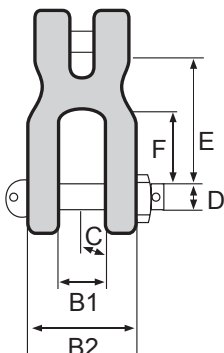

CLEVIS SHACKLE

PRODUCT CODE	Chain size mm	Dimensions mm							Mass kg
		WLL	E	D	C	F	B1	B2	
DO61150-30	10,0	3,15	64	16	32	36	21	47	0,62
DO61150-31	13,0	5,3	83	20	40	49	27	61	1,16