

# Tusker® lever hoists

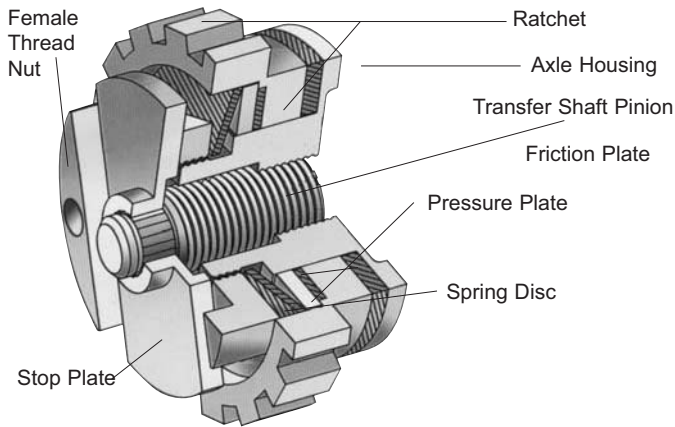

- Rugged Steel Body
- Light Mass, Compact and Portable
- Short 360° Rotating Handle
- Low Handle Effort
- Easy Free Chain Pull
- Impact Resistant
- Swivel Type Hooks Complete with Safety Latches
- McKinnon Grade 1 000 Load Chain
- Lower Hook Opening Before Chain Failure as a Safety Precaution

Product Code Model No	YL-030	YL-050	YL-080	YL-100	YL-160	YL-320	YL-600	
Rated capacity (ton)	0.3	0.5	0.8	1.0	1.6	3.2	6.0	
Lift Height (m)	1.0	1.5	1.5	1.5	1.5	1.5	1.5	
Chain dia (mm)	4.0	5.0	5.6	6.3	7.1	9.0	9.0	
Net Weight (kg)	2.1	3.9	6.1	7.0	10.7	16.2	31	
Min distance between hooks (G) (mm)	235	275	290	325	370	470	620	
Length of operating handle (n) (mm)			265	265	400	416	416	
Pull on lever to lift full load (kgf)	30	35	25	30	30	36	38	
Dimensions mm	A	72	88	100	100	99	104	104
	B	23	26	55	55	65	81	81
	C	67	93					
	D			80	80	103	120	164
	E			41	41	47	55	62
	G	235	275					
	N	155	265					
F1	23	28	28	36	38	50	50	



● OPTIONAL OVERLOAD PROTECTION

