

FA - 3 Phase, Single Speed

Features:

- Designed and equipped for inverted or normal positions
- Designed for load chain collection whether normal or inverted position
- Load spectrum conforms to FEM 2m / ISO M5 covering a wide range of applications
- Mat black non-reflecting coating
- Hooks with hot forged and heat treatment allow to be swivelled 360° and are equipped with safety latch to ensure proper hooking the load
- MC Nylon is applied to Load Chain Guide to ensure the load chain's proper fitment through the load sheave during operation and protecting the load sheave from moisture and dust
- Overload clutch protects hoist from damage and ensures a long working life
- Operation at high efficiency (40%ED), is quiet, light weight and versatile
- Independent heavy-duty DC brakes on hoist motors eliminate heat rise and control the load securely
- Phase error relay as standard prevents motor from running when the phase is incorrectly connected
- Operates on single voltage between 220V~550V, 3 ph, 50 or 60 hz
- Low control voltage 48V as standard for operator safety; other control voltages are available on request

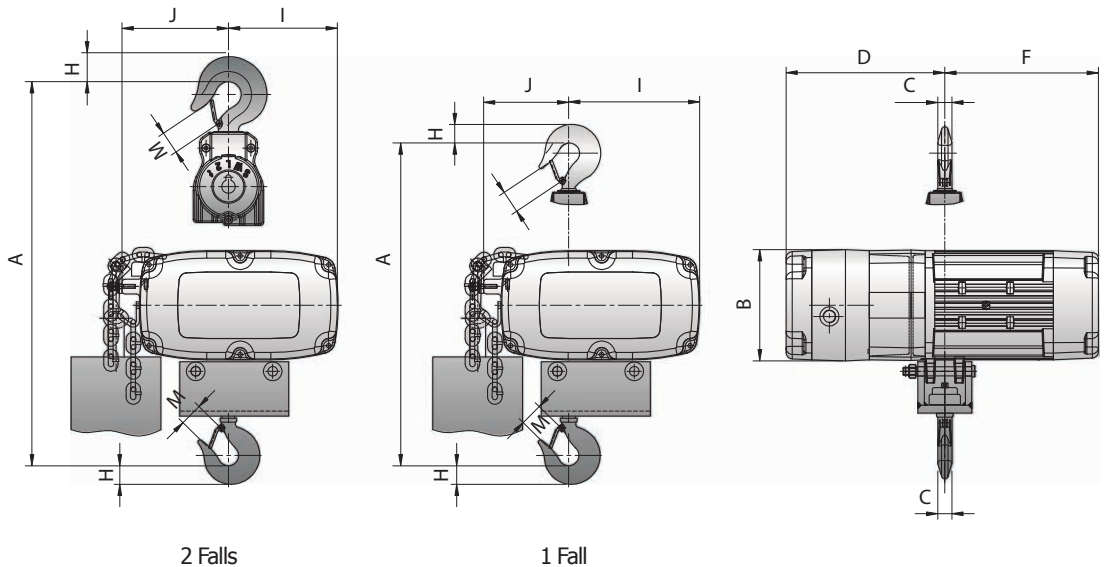

Capacity	Model	Speed (m/min)		Fall No.	Load Chain (Dia x Pitch) (mm)	Motor (Kw x Pole)	Weight of Hoist (kg)	Dimensions (mm)								
		50Hz	60Hz					A	B	C	D	F	H	I	J	M
250	SH-025-1	3.3	4.0	1	0 4 X 12	0.25 X 4	30	410	135	18	205	175	28	165	85	25
1000	SH-100-1	3.3	4.0	1	0 7.1 X 20.2	0.75 X 4	47	600	156	23	247	221	33	185	105	30
500	SH-050-1	3.3	4.0	1	0 6.3 X 19.1	0.4 X 4	42	620	156	23	247	221	33	185	105	30
2000	SH-200-2	3.3	4.0	2	0 7.1 X 20.2	1.5 X 2	62	700	170	27	275	240	39	170	170	30